

BRG	X-LOC	REACT	SIZE
1	0- 1-12	475	3.50"
2	1- 0- 9	148	3.50"
3	2- 1- 2	205	3.50"
4	3- 6- 0	212	3.50"
5	4-10-14	190	3.50"
6	6- 3-12	295	3.50"
7	6- 6- 0	178	3.50"
8	7-10- 9	182	3.50"
9	9- 3- 1	197	3.50"
10	10- 7-10	475	3.50"
11	10-10- 0	591	3.50"
12	12- 2- 9	200	3.50"
13	13- 7- 1	210	3.50"
14	14-11-10	459	3.50"
15	15- 2- 0	456	3.50"
16	16- 6- 9	209	3.50"
17	17-11- 3	185	3.50"
18	19- 3-12	246	3.50"
19	19- 6- 0	281	3.50"
20	20-11- 1	179	3.50"
21	22- 4- 2	209	3.50"
22	23- 9- 3	228	3.50"
23	24-10- 9	167	3.50"
24	25-10- 4	456	3.50"

TC	FORCE	AXL	BND	CSI	ID	SCRWS
OL-1	91	0.02	0.68	0.68	1	
1-2	-118	0.02	0.60	0.62	1	
2-3	-146	0.03	0.44	0.47	1	
3-4	-53	0.01	0.43	0.44	1	
4-5	274	0.05	0.57	0.59	1	
5-6	212	0.03	0.70	0.71	1	
6-7	430	0.03	0.70	0.70	1	
7-8	145	0.00	0.18	0.18	1	
8-9	183	0.01	0.08	0.09	1	
9-10	367	0.02	0.70	0.70	1	
10-11	158	0.03	0.70	0.70	1	
11-12	252	0.04	0.58	0.60	1	
12-13	-67	0.01	0.46	0.47	1	
13-14	-128	0.02	0.46	0.48	1	
14-15	-108	0.02	0.60	0.62	1	
15-OR	91	0.02	0.68	0.68	1	

BC	FORCE	AXL	BND	CSI	ID	SCRWS
16-17	0	0.00	0.07	0.07	1	
17-18	-155	0.03	0.07	0.09	1	
18-19	0	0.00	0.09	0.09	1	
19-20	0	0.00	0.09	0.09	1	
20-21	0	0.00	0.08	0.08	1	
21-22	0	0.00	0.09	0.09	1	
22-23	0	0.00	0.09	0.09	1	
23-24	0	0.00	0.09	0.09	1	
24-25	0	0.00	0.09	0.09	1	
25-26	0	0.00	0.09	0.09	1	
26-27	0	0.00	0.08	0.08	1	
27-28	-79	0.01	0.06	0.07	1	
28-29	9	0.00	0.08	0.08	1	

WEB	FORCE	CSI	ID	SCRWS
1-16	-467	0.09	1	
2-17	81	0.01	1	
3-18	-132	0.11	1	
4-19	-355	0.30	1	
5-20	-97	0.18	1	
6-21	-500	0.93	1	
7-22	-599	0.70	1	

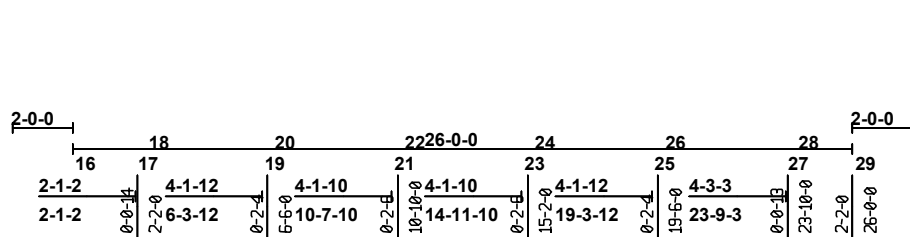
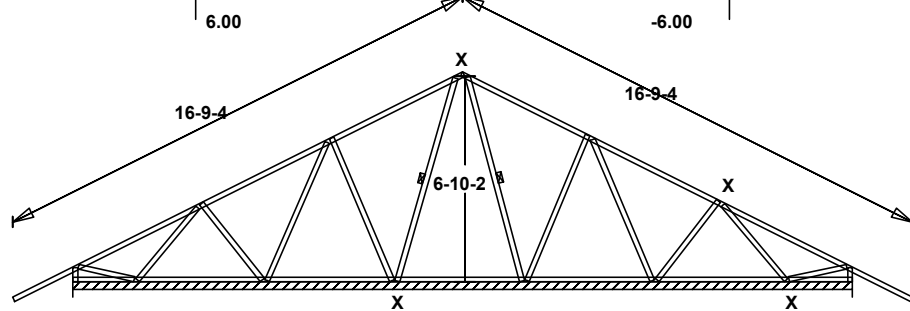
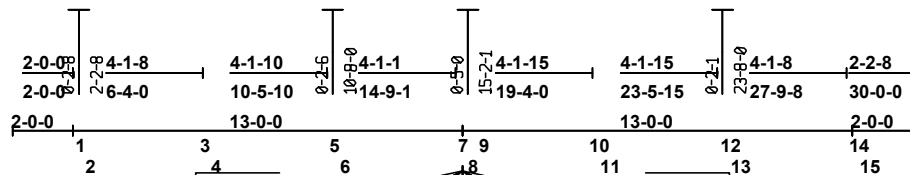

OVER CONTINUOUS SUPPORT

Scale: 5/32" = 1'

**NUTRUSSTM**  
A NUCONSTEEL Product

**WARNING** Read all notes on this sheet and verify all design parameters.  
Truss design on this sheet is only valid with NUTRUSST sections and is for an individual building component, not a truss system. Bracing shown on this drawing is not erection bracing, wind bracing, portal bracing or similar bracing which is part of the building design and which must be considered by the building designer. Bracing shown is lateral bracing of truss members only. Any additional bracing, temporary and/or permanent, is the responsibility of the truss erector and/or the building designer. The Professional Engineer's seal indicates only that the truss assembly shown on this sheet meets the acceptable design criteria for the loads, loading condition, truss configuration and spans specified.

Designer:		WO: C61226E_Trusses
Dsgn Chk:		
Engg Chk:		
Cutting :		
TC Live	42.00 psf	Design Spec: AISI S100-2012
TC Dead	10.00 psf	Buildg Spec: IBC-2018
BC Live	0.00 psf	
BC Dead	10.00 psf	
TOTAL	62.00 psf	Date: 11/23/2022@ 18:31:41
		Seqn S8.1.0a - 6309